

Net Present Value of 30 year-energy-saving for facade refurbishment strategies

		1	2	3
		Completely Glazing A_g/A_{tot} 90%	Bipartite A_g/A_{tot} 90%	Tripartite A_g/A_{tot} 90%
				
1	Selective/Low E Glazing No shading device	114 €/m ²	124 €/m ²	136 €/m ²
2	Low E Glazing External roller shade	129 €/m ²	135 €/m ²	143 €/m ²
3	Low E Glazing External venetian blind	125 €/m ²	131 €/m ²	141 €/m ²

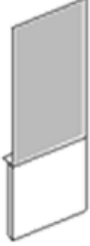

Building electric storage system
Using second-life e-car batteries
Solar power generation and batteries connected in a dedicated microgrid at building level

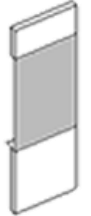